

# HOE 3011

## 10/100M Media Converter (SM or MM Fiber)



### Overview

This series of product supports IEEE802.3UI100Base-Tx/Fx protocol, as well as full duplex and half duplex mode. This specification is for adaptive 100M, 10M/100M transceivers.

### Main features

1. In conformity to IEEE 802.3 10 Base-T standard.  
In conformity to IEEE 802.3u 100 Base-TX/FX standard.
2. Max. 2M buffer memory built in chip.
3. Back pressure flow control for full duplex IEEE802.3 X and half duplex.
4. Automatic identification of MDI/MDI-X cross line.
5. High-performance 1.4Gbps memory bandwidth.
6. In conformity to safety code of FCC and 15 CLASS A and CE MARK.

### Technical parameters:

1. Standard Protocol: IEEE802.3 10 Base-T standard  
IEEE 802.3u 100Base-TX/FX standard
2. Connector: one UTP RJ-45 connector, one SC/ST connector
3. Operation mode: full duplex mode or half duplex mode
4. Power supply parameter: outside: 5V DC 1A  
built-in: 110-240V AC 48VDC
5. Environmental temperature: 0°C-60°C
6. Relative humidity: 5%-90%
8. TP cable: Cat5 UTP cable
9. Transfer fiber:  
Multi-mode: 50/125, 62.5/125 or 100/140µm  
Single mode: 8.3/125, 8.7/125, 9/125 or 10/125µm
10. Dimensions:

External power supply: 26mmx 71mm x 94mm  
 Built-in power supply: 40mm x 110mm x 140mm

### Explanation for LED indicator lamp

LED indicator lamps serve as device monitoring and trouble display. The following is the explanation for each LED indicator lamp.

LED indicator lamp	Status	Explanation
FX Link/Act	On	Connection status display for fiber link. "ON" indicates that Fiber link is in correct connection.
	Blink	Active status display of fiber link "Blink" indicates packet goes through Fx end.
TX Link/Act	On	Connection status display for electric link. "ON" indicates that electric link is in correct connection.
	Blink	Active status display of fiber link "Blink" indicates packet goes through Tx end.
FDX	On	Transceiver works in the full duplex mode.
	Off	Transceiver works in the half duplex mode.
PWR	On	Power is on and normal.
FX	On	Transfer rate of optical interface is 100Mbps.
TX	On	Transfer rate of electric interface is 100Mbps.
	Off	Rate of electric interface is 10Mbps

## Installation

### 1. Interface

#### RJ-45 interface

The transmission media adopts CAT5 twisted-pair with typical length of 100 meter. It features the function of automatically identifying the through line and cross wire (10/100M).

#### Fiber interface

SC/ST fiber interface is of duplex mode type, including two interfaces, namely TX and RX. When the two sets of optical transceiver are interfaced or connected to switch with fiber interface, the fiber is in cross connection, namely "TX-RX", "RX-TX" (direct butting for single optical fiber).

### 2. Connection

The network device (work station, hub or switch) with RJ-45 interface is connected to RJ-45 jack of optical transceiver through twisted-pair. And the multi/single mode fiber is connected to SC/ST fiber

interface of the optical transceiver. Then switch on. The corresponding LED is on for correct connection. (See the table below for the LED indicator lamp)

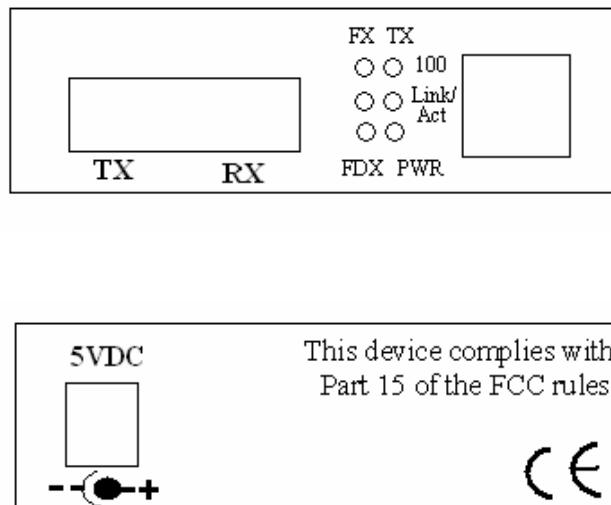

**Figure 1 Schematic drawing of connection**

**Cautions:**

1. This product is suitable for indoor application.
2. Put on the dust cover of fiber interface when not used.
3. It is forbidden to stare at the TX fiber-transfer end with naked eyes.
4. Single optical fiber transceiver must be used in pair (See the attachment description in delivery).

**Trouble shooting:**

1. Device is not matched. Please select the corresponding network device according to the transfer rate of the product (10Mbps or 100Mbps) when connected to other network devices (network card, hub, switch).
2. Line loss is excessive during the fiber wiring. Excessive loss in connector plug-in and fiber soldering welding, and excessive intermediate nodes may cause excessive loss rate or abnormal operation.